

EP9307 CPU

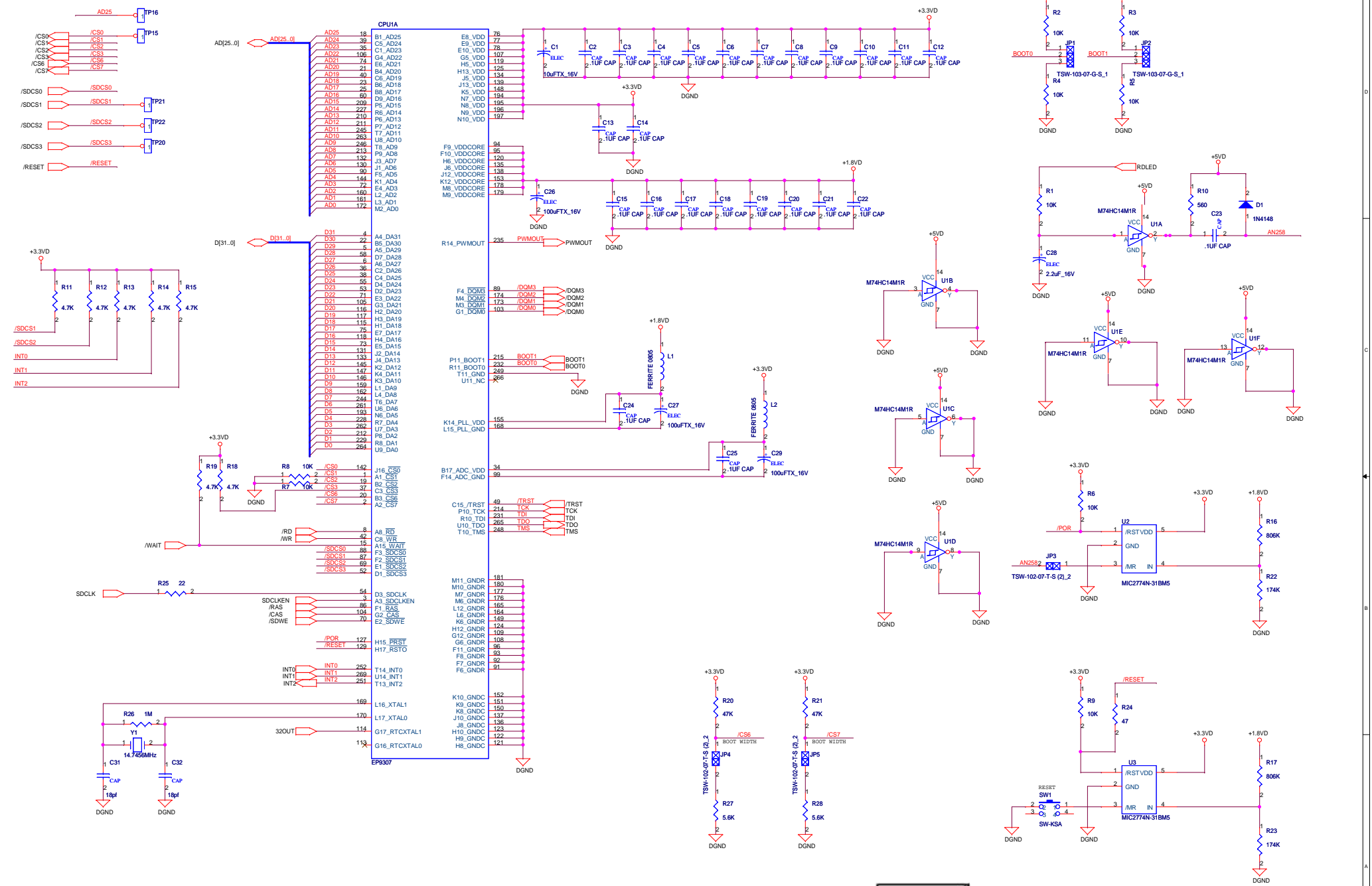

Title		EP9307 CPU
Size	Document Number	2198
C	Rev	1.3
Date:	Saturday, September 19, 2009	Sheet 1 of 13

EP9307 INTERNAL DEVICES

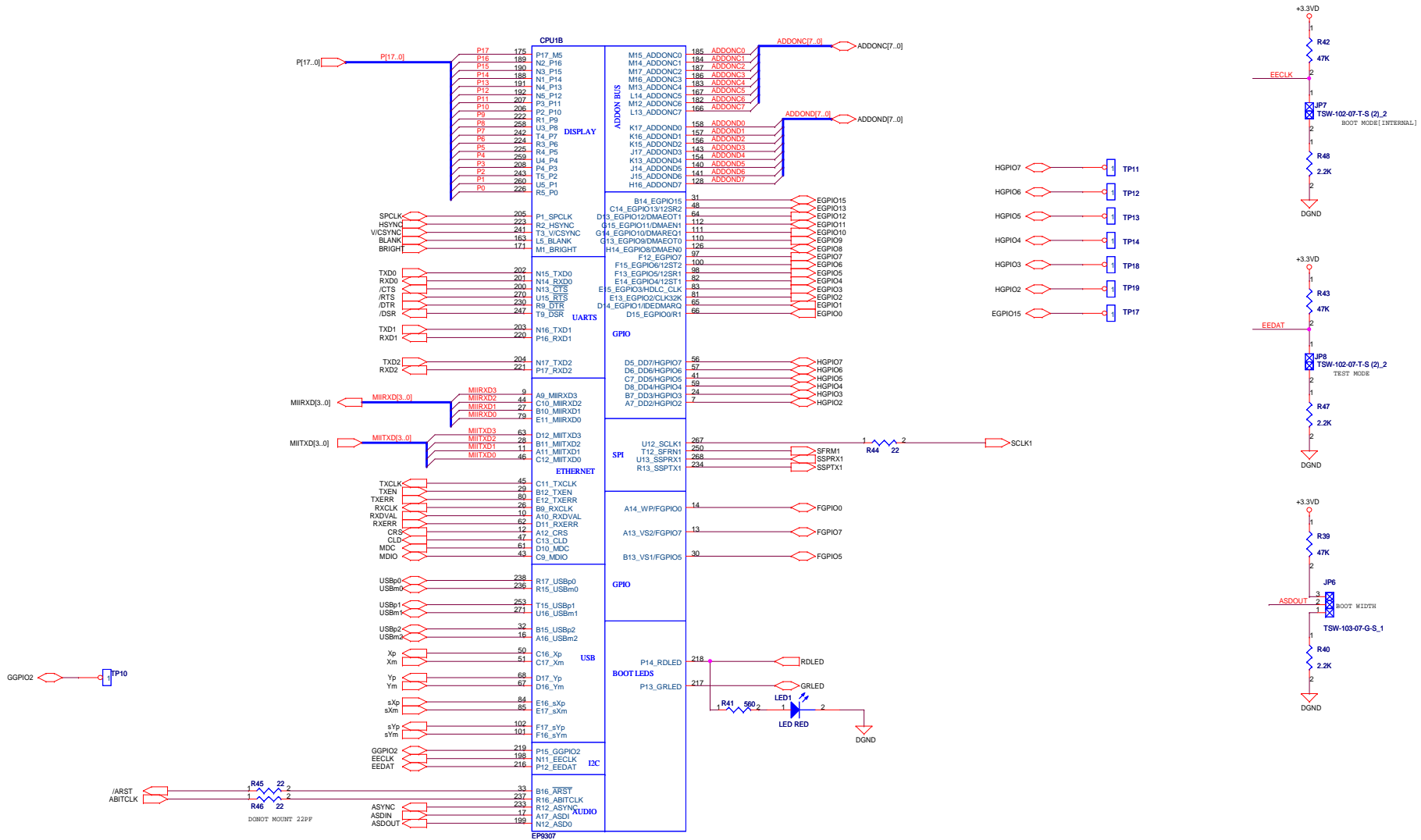

# INTERNAL LCD CONNECTOR

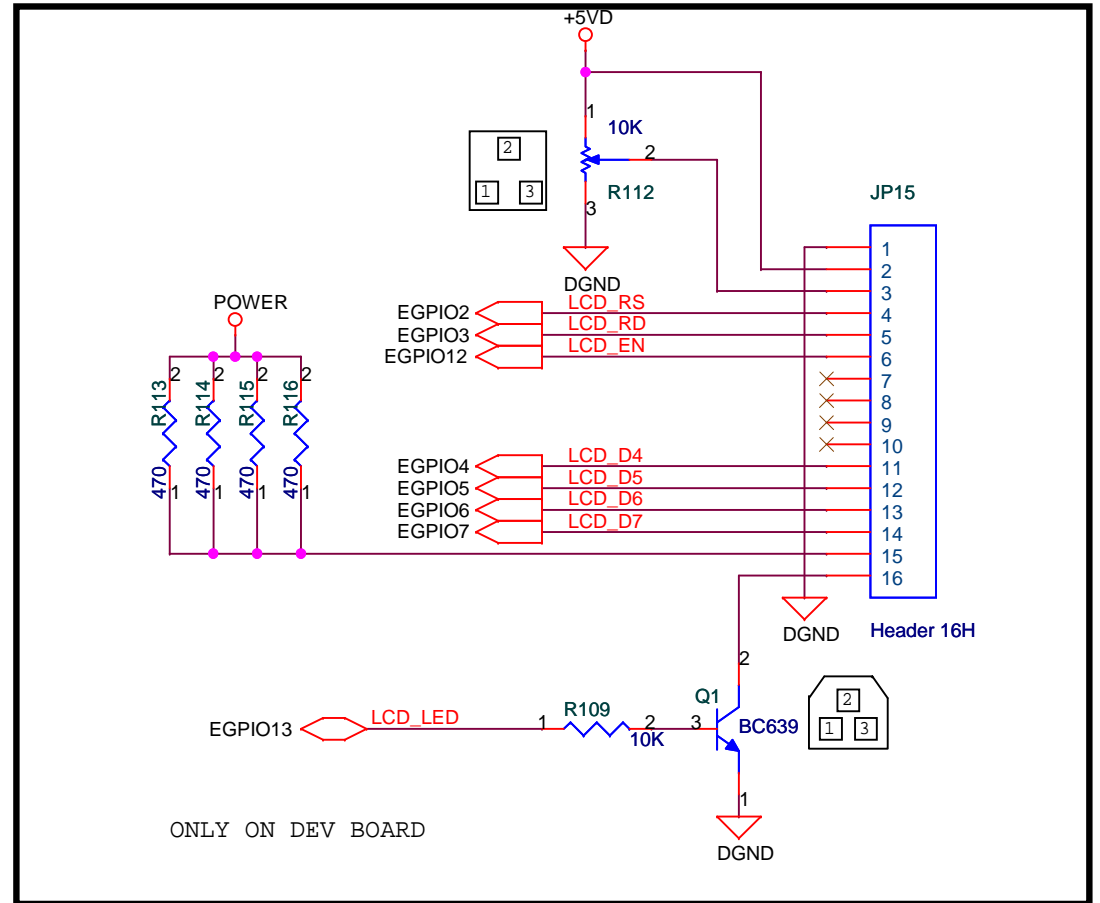
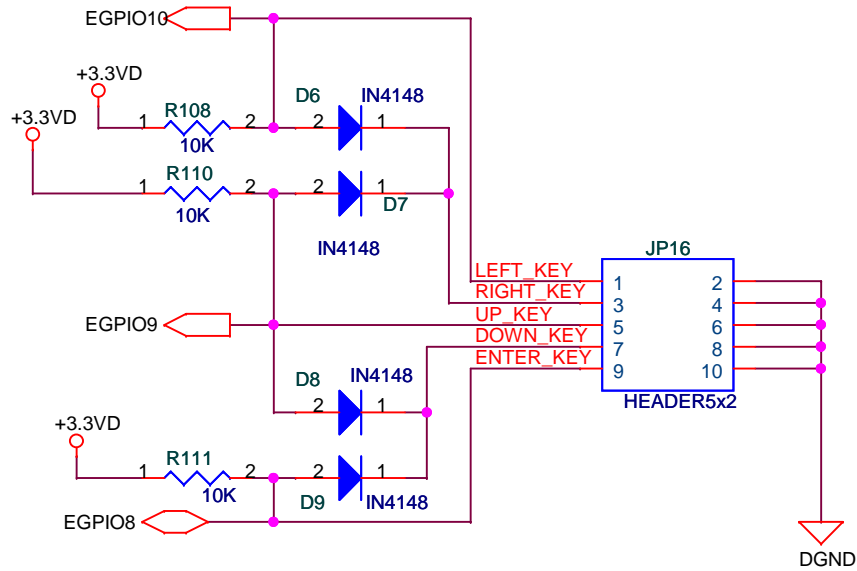

Title		
INTERNAL LCD CONNECTOR		
Size	Document Number	Rev
A	2198	1.3
Date:	Saturday, September 19, 2009	Sheet 3 of 13

# ADDON BUS CONNECTOR

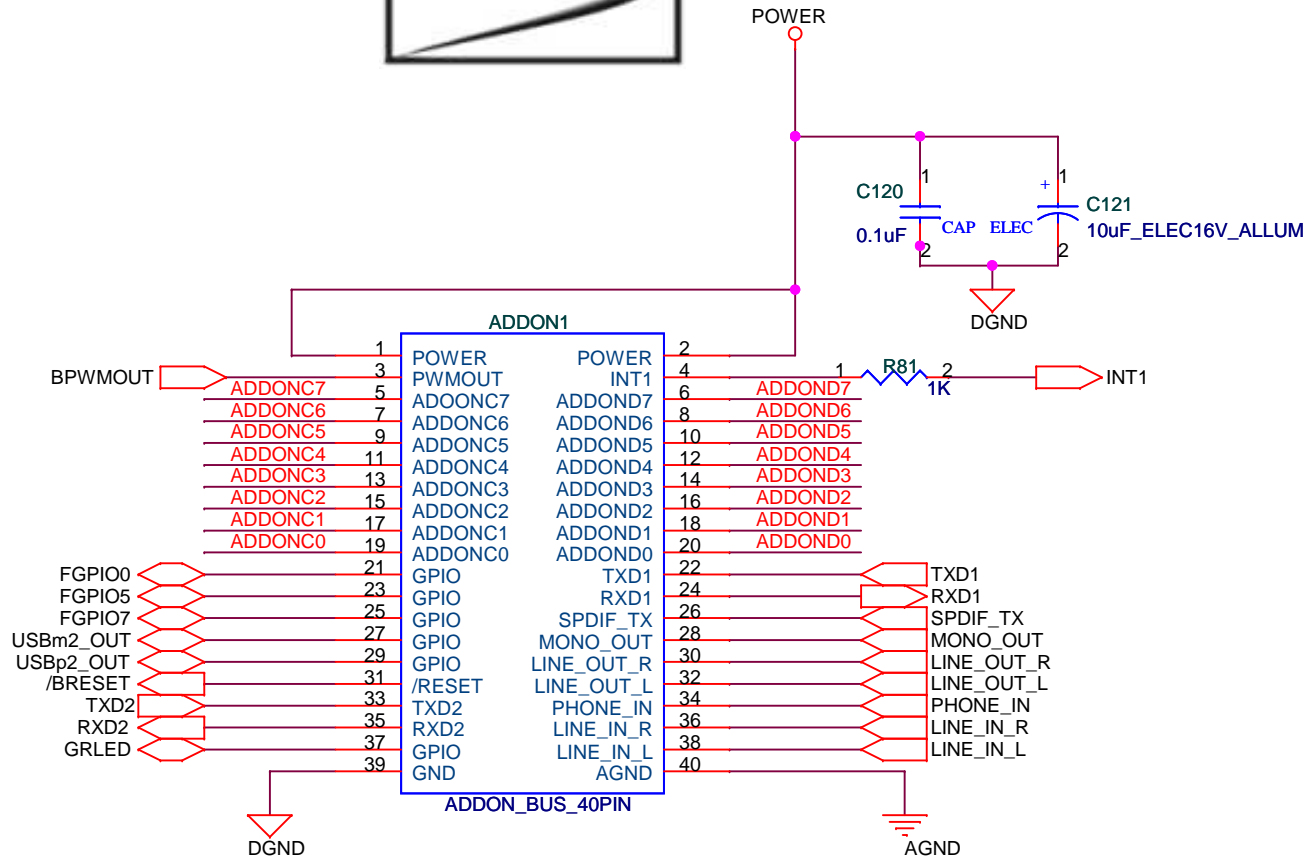
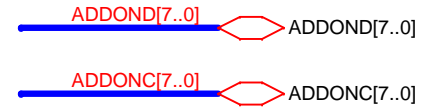

Title		
ADDON BUS CONNECTOR		
Size	Document Number	Rev
A	2198	1.3
Date:	Saturday, September 19, 2009	Sheet 4 of 13

# 8MB, 16bit FLASH

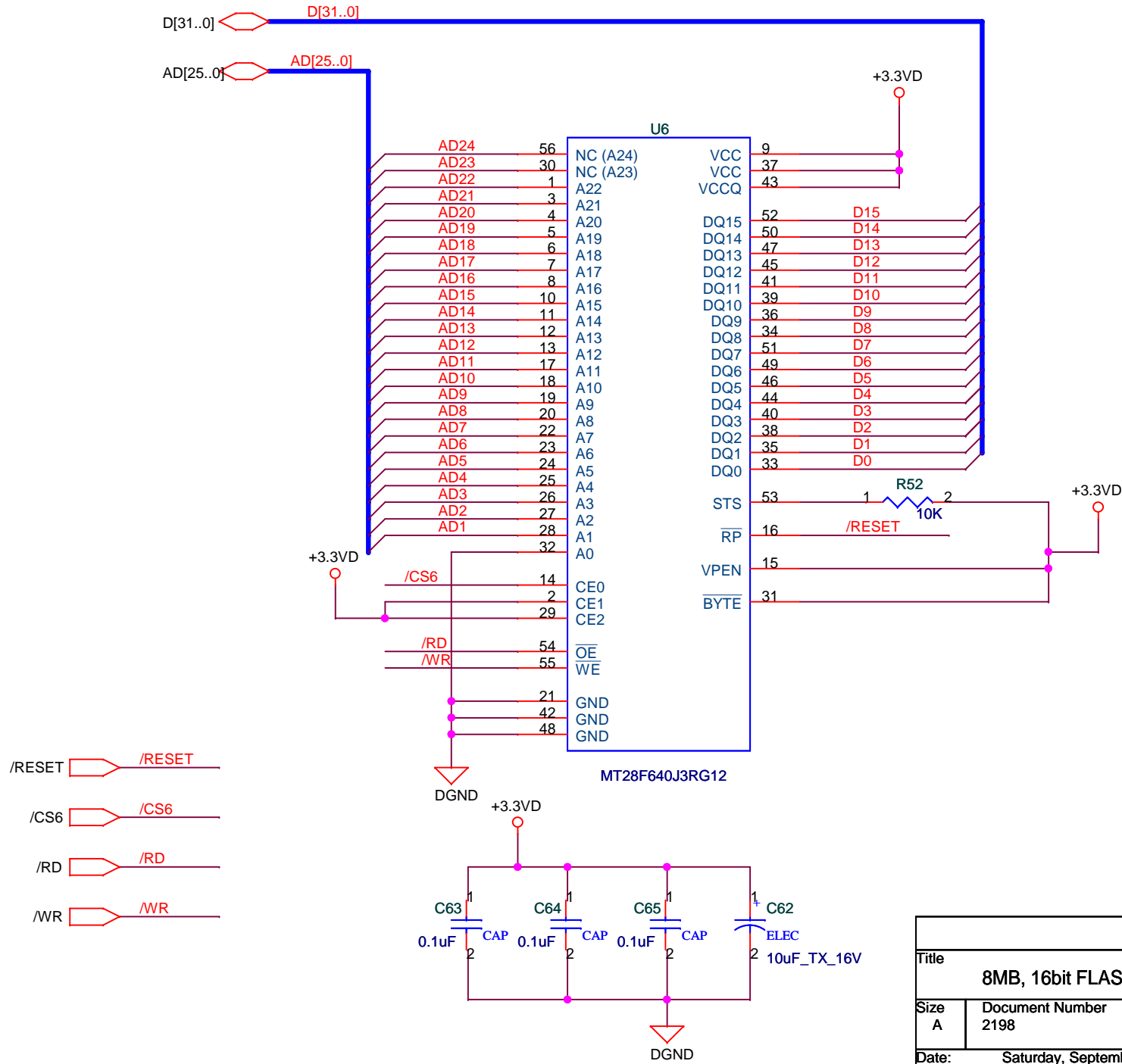

Title		
8MB, 16bit FLASH		
Size	Document Number	Rev
A	2198	1.3
Date:	Saturday, September 19, 2009	Sheet 5 of 13

# LCD EXT. CONNECTOR

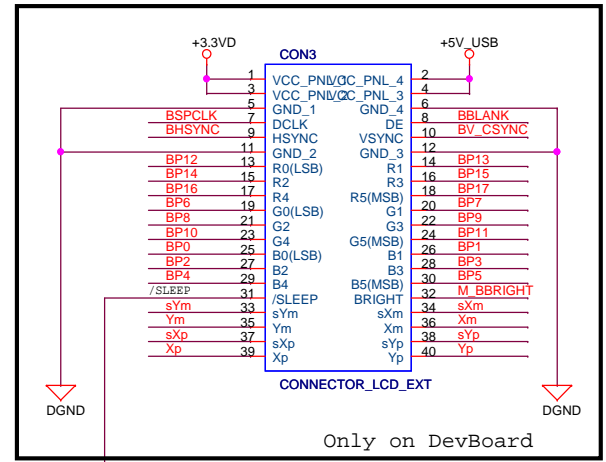
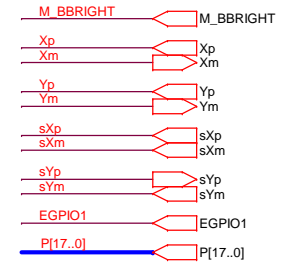
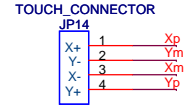
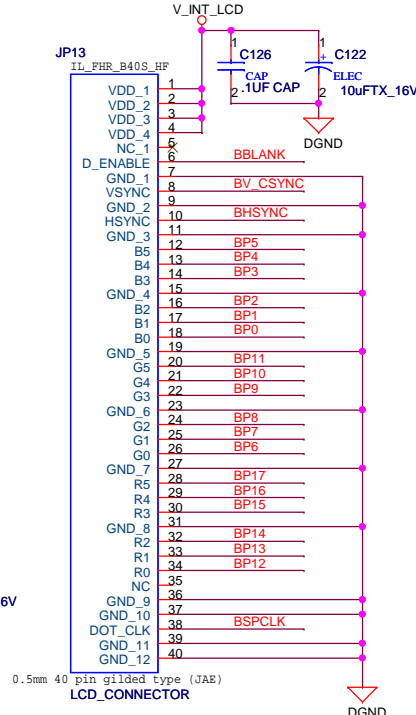
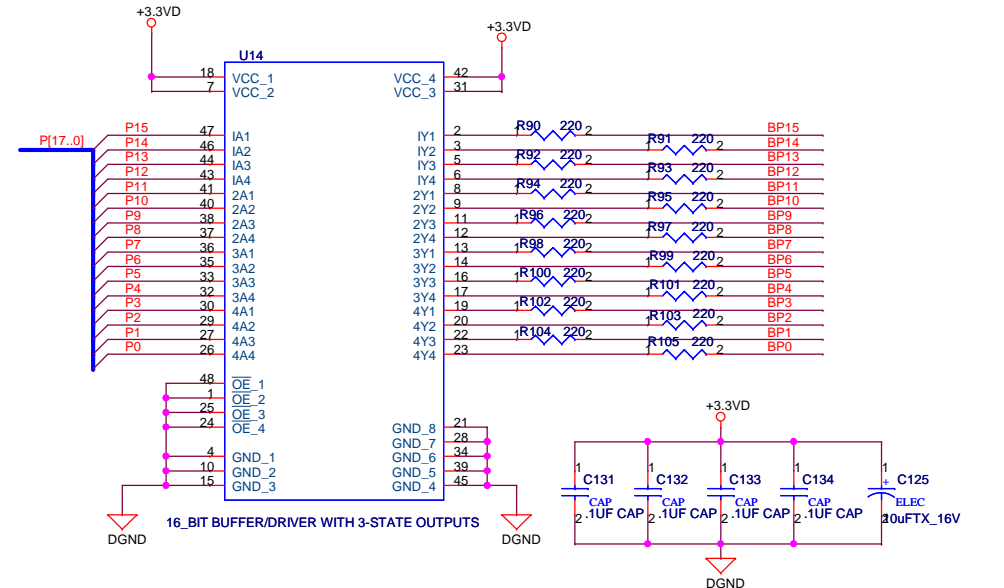
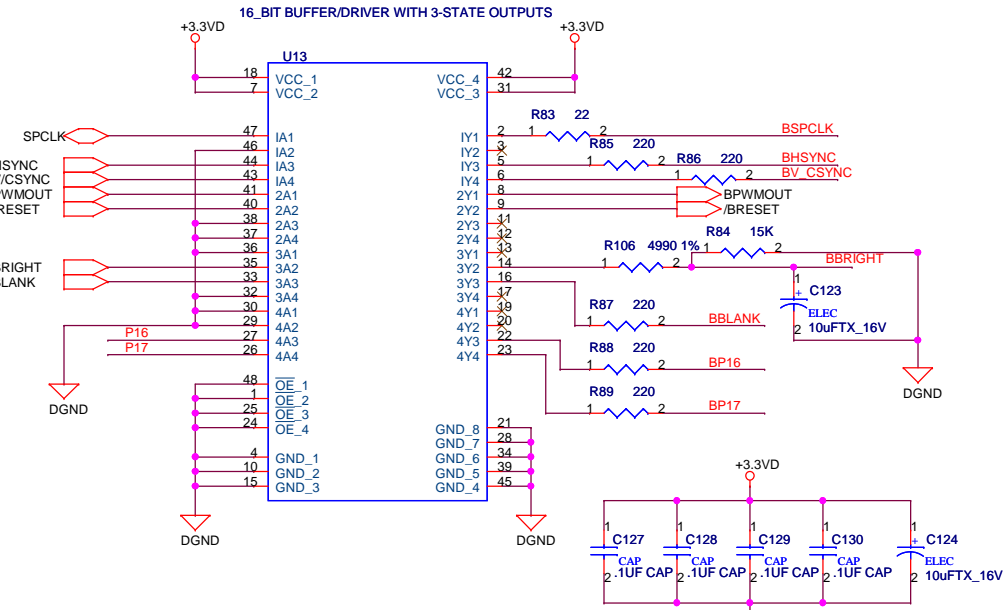

Only on DevBoard

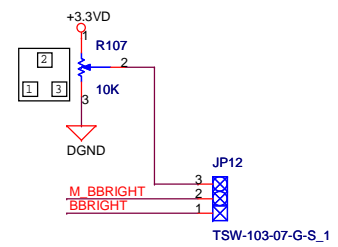

Title		
LCD EXT. CONNECTOR		
Size	Document Number	Rev
B	2198	1.3
Date:	Saturday, September 19, 2009	Sheet 6 of 13

# VGA & CONNECTOR

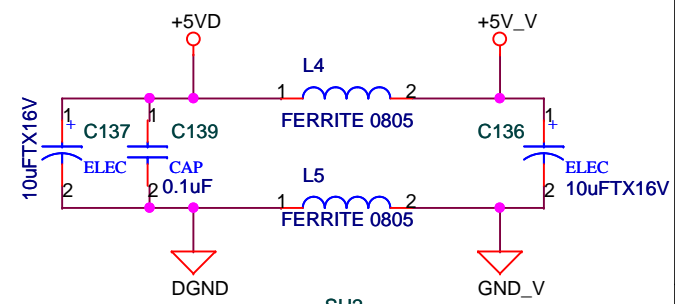
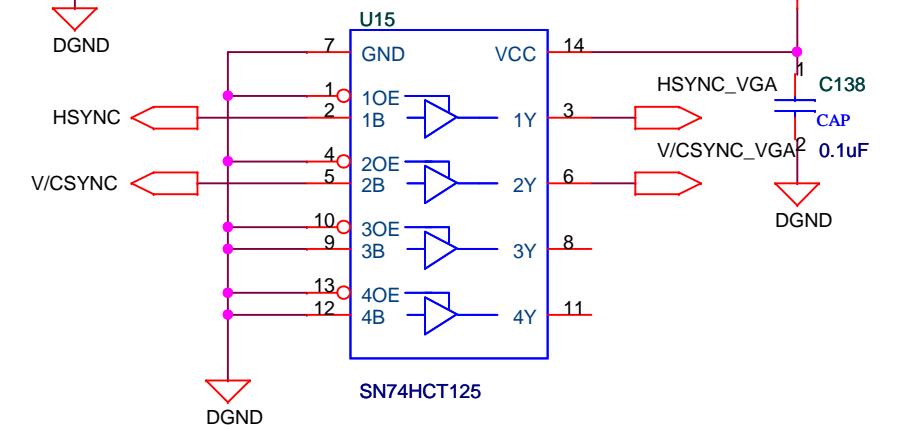
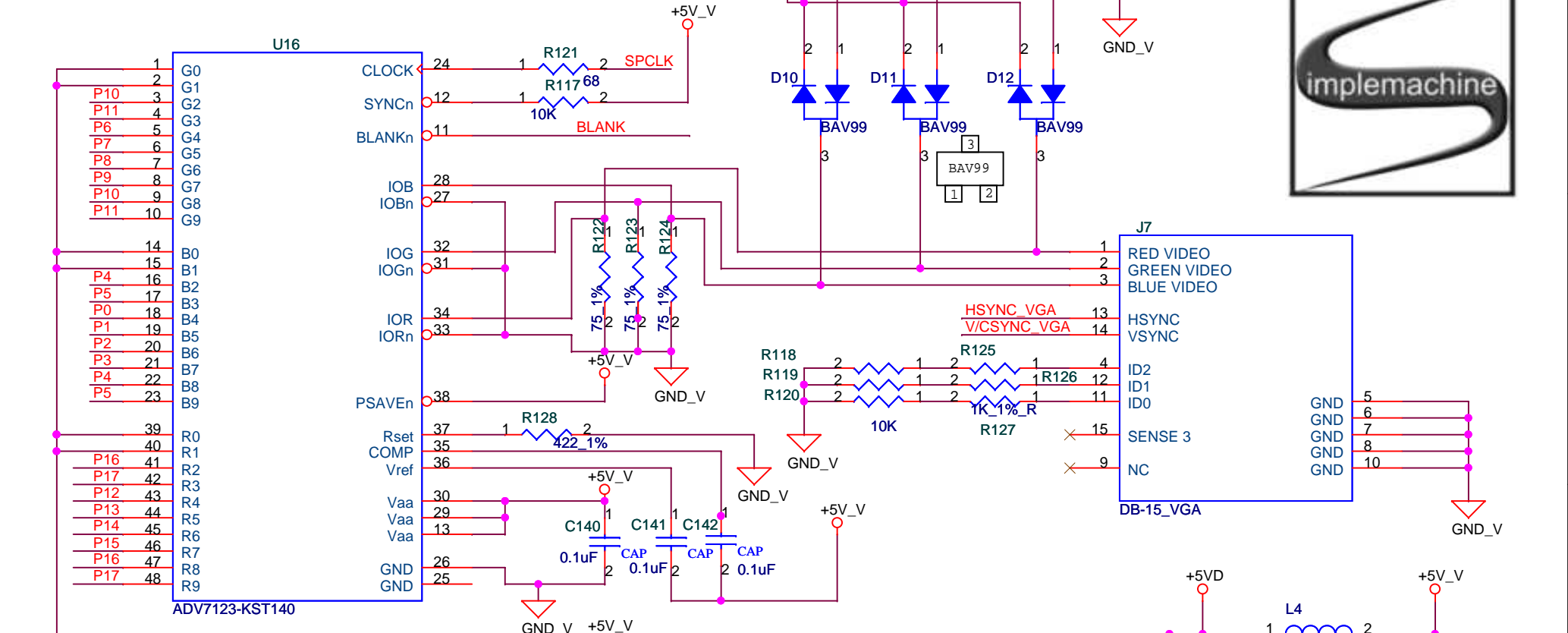
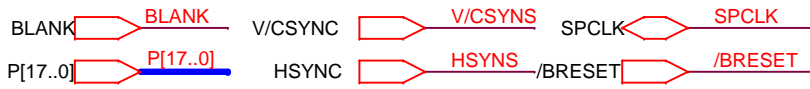

SH2 RESISTOR CAN BE USED AS A SHORT FOR DGND AND GND\_V

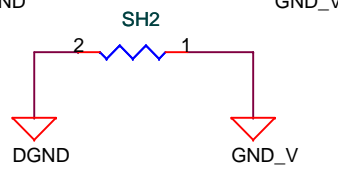

Title		
VGA & CONNECTOR		
Size	Document Number	Rev
A	2198	1.3
Date:	Saturday, September 19, 2009	Sheet 7 of 13

# NETWORK

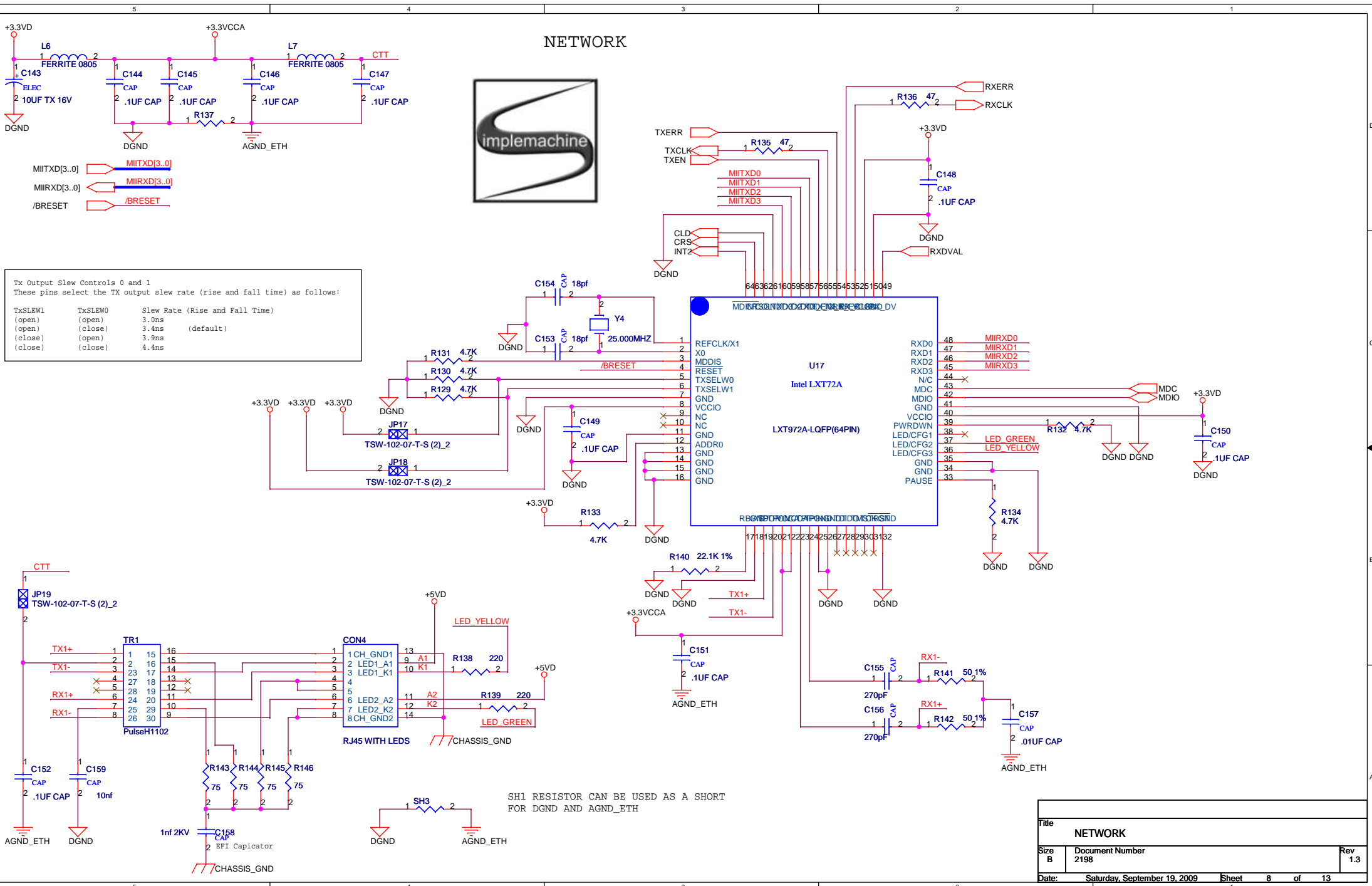

Tx Output Slew Controls 0 and 1  
 These pins select the TX output slew rate (rise and fall time) as follows:

TxSLEW1	TxSLEW0	Slew Rate (Rise and Fall Time)
(open)	(open)	3.0ns
(open)	(close)	3.4ns
(close)	(open)	3.9ns
(close)	(close)	4.4ns

SH1 RESISTOR CAN BE USED AS A SHORT FOR DGND AND AGND\_ETH

Title		
NETWORK		
Size	Document Number	Rev
B	2198	1.3
Date:	Saturday, September 19, 2009	Sheet 8 of 13



# 64MB, 32bit SDRAM

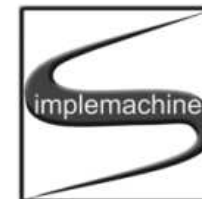
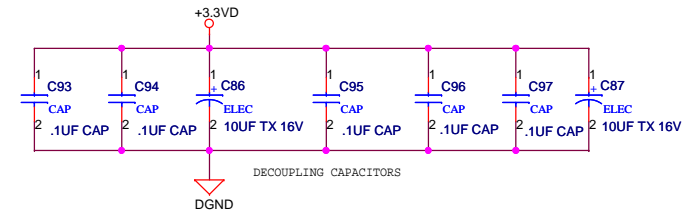
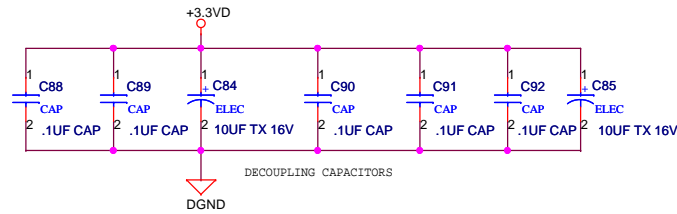
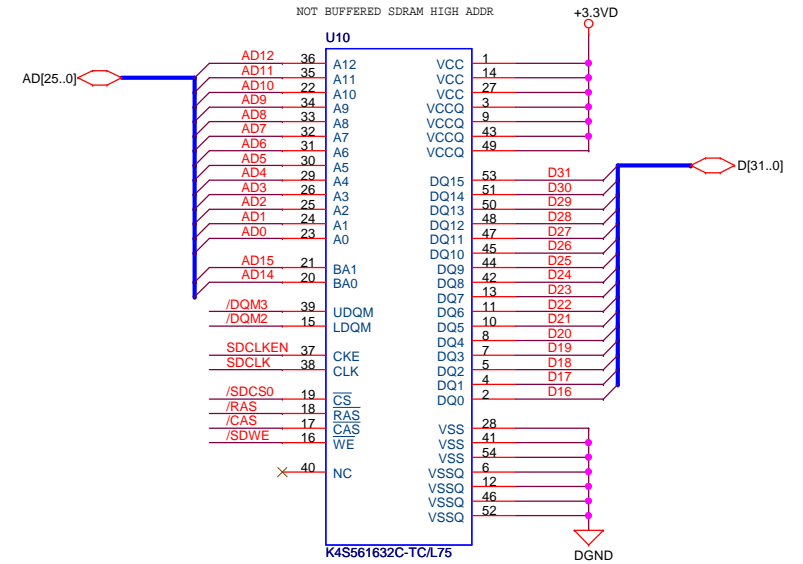
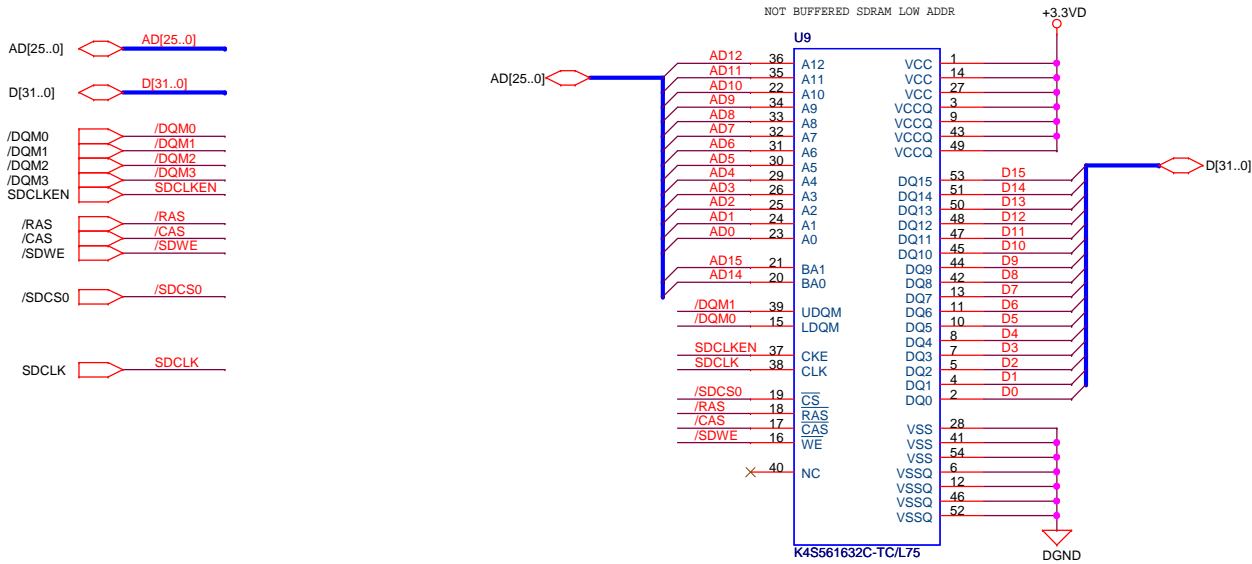

Title		
64MB, 32bit SDRAM		
Size	Document Number	Rev
B	2198	1.3
Date:	Saturday, September 19, 2009	Sheet 9 of 13

# UART AND SD/MMC CONNECTORS

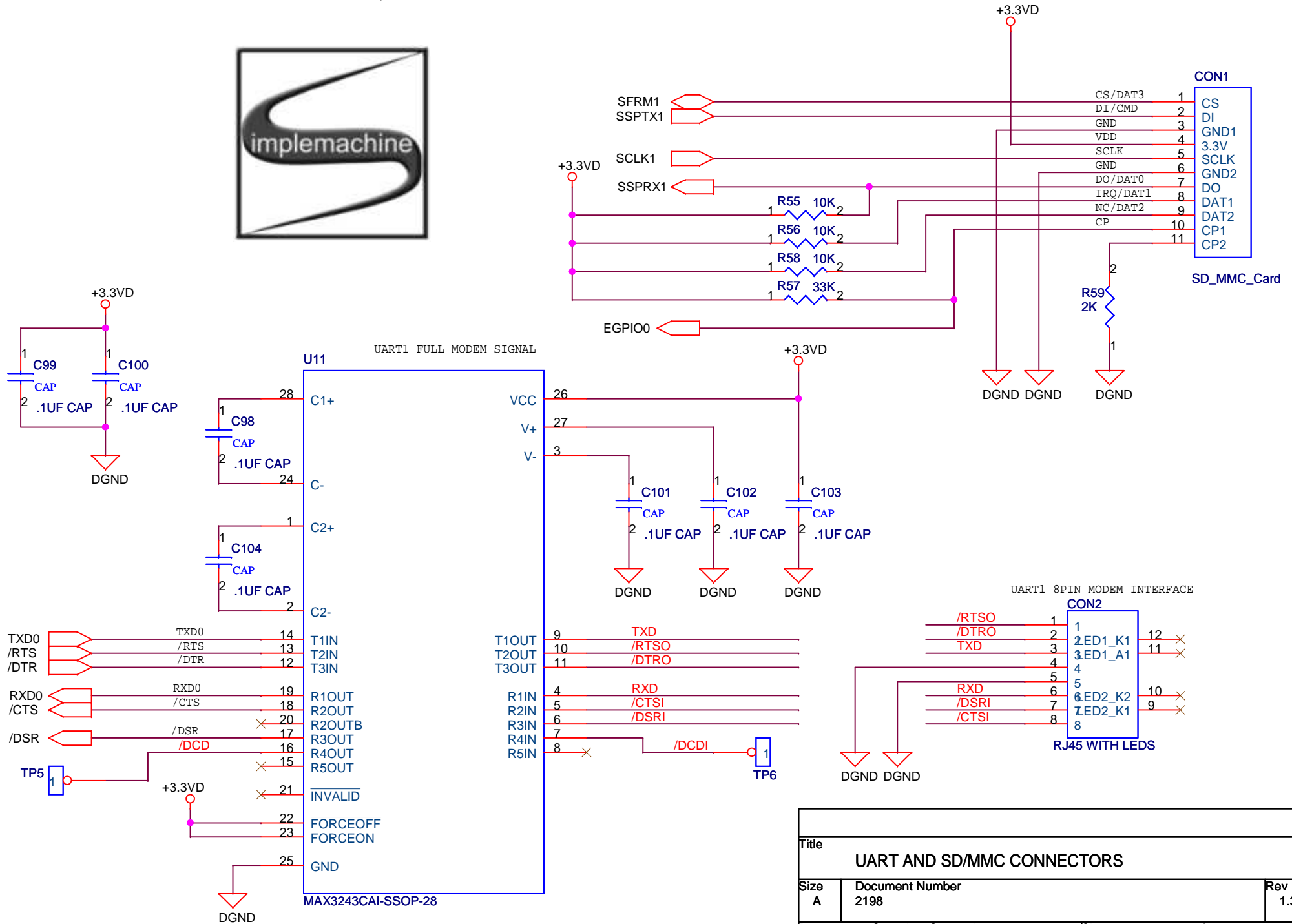

Title		
UART AND SD/MMC CONNECTORS		
Size	Document Number	Rev
A	2198	1.3
Date:	Saturday, September 19, 2009	Sheet 10 of 13

# USB, RTC & JTAG

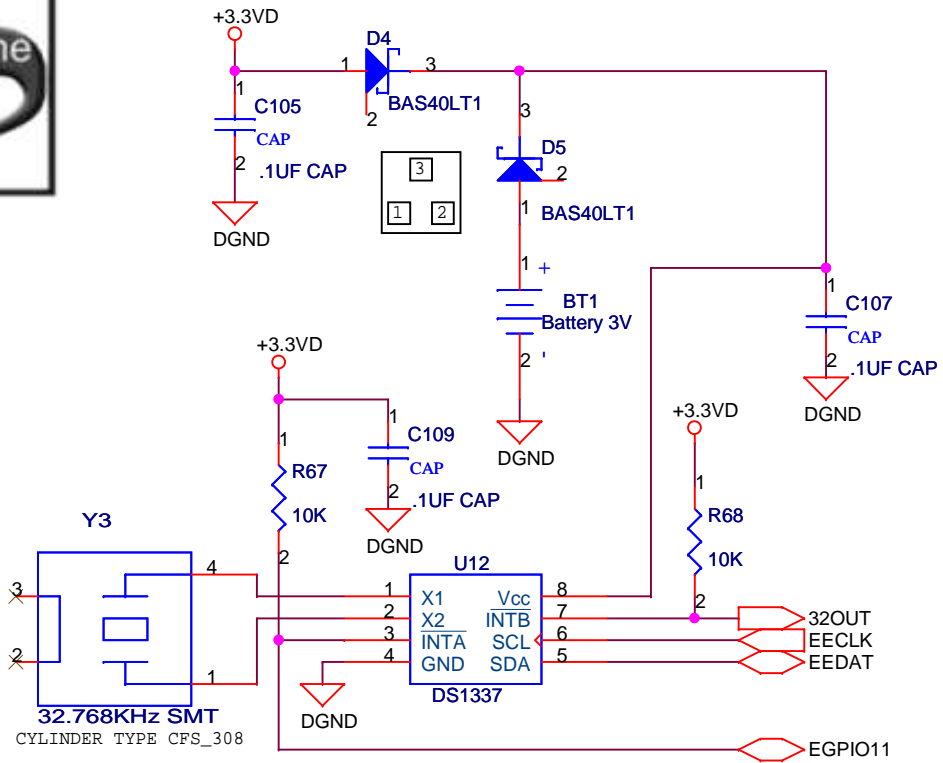
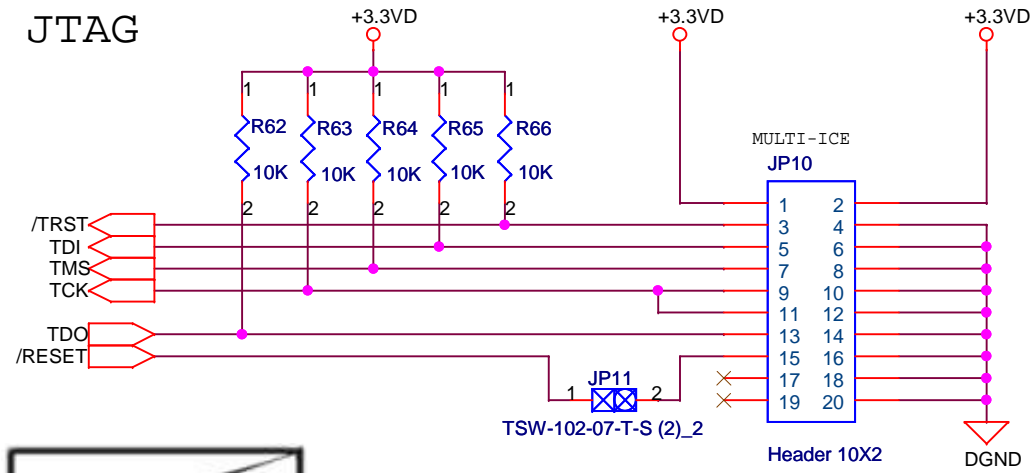
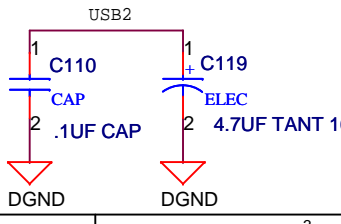
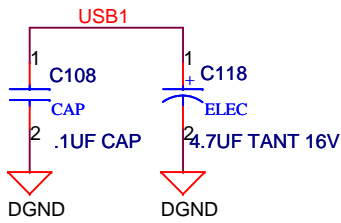
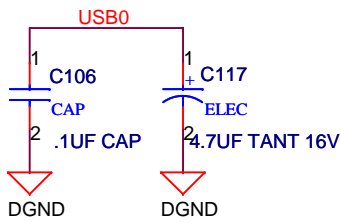
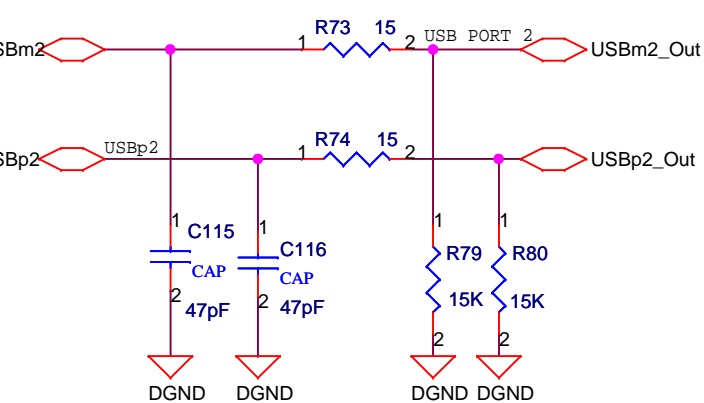
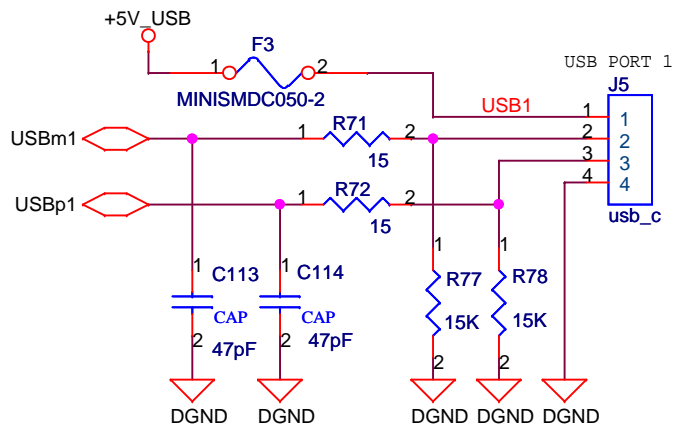
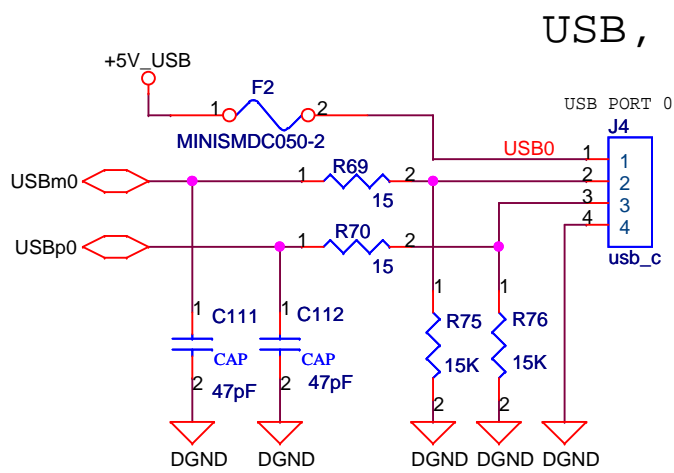

Title		
USB, RTC & JTAG		
Size	Document Number	Rev
A	2198	1.3
Date:	Saturday, September 19, 2009	Sheet 11 of 13

# AUDIO & JACK CONNECTORS

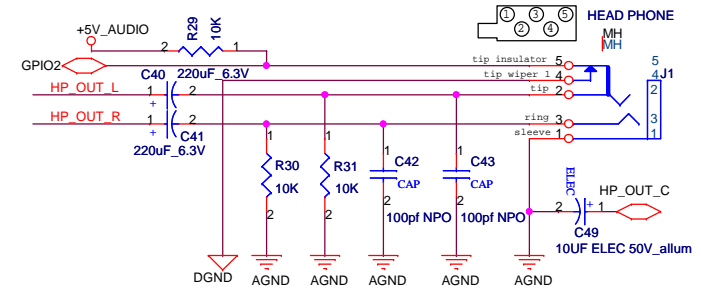
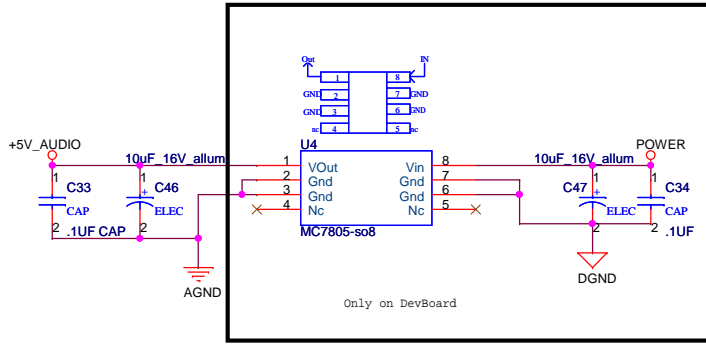
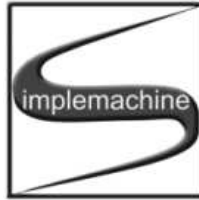

SH1 RESISTOR CAN BE USED AS A SHORT FOR AGND AND DGND

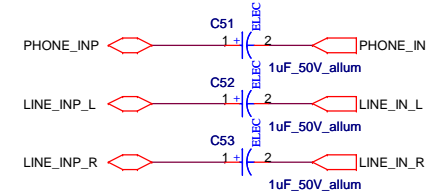
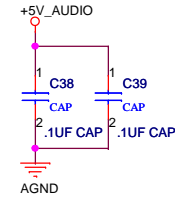
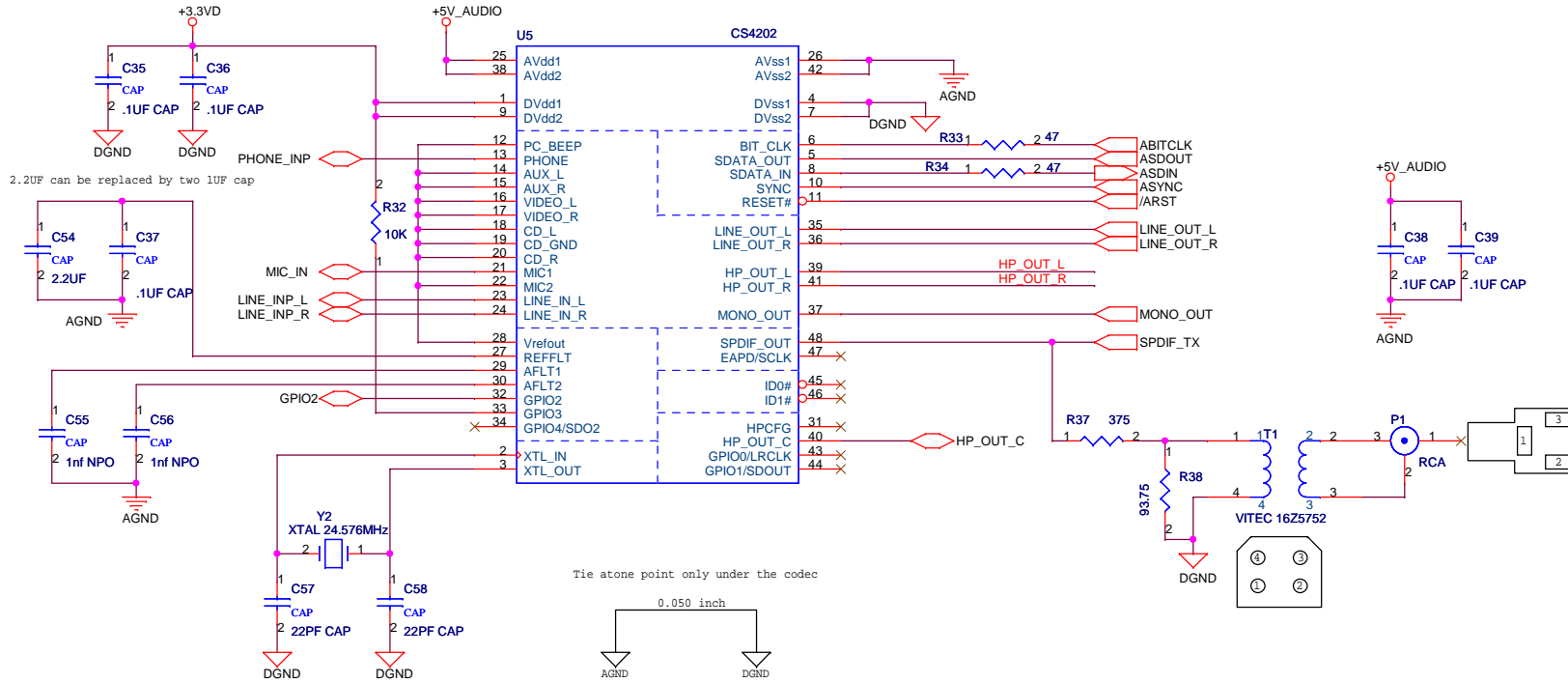
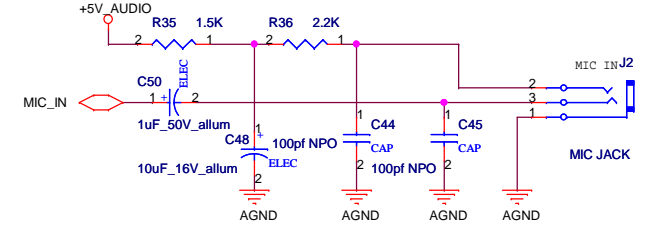
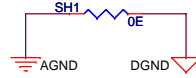

Title		
AUDIO & JACK CONNECTORS		
Size	Document Number	Rev
B	2198	1.3
Date:	Saturday, September 19, 2009	Sheet 12 of 13

# POWER SUPPLY

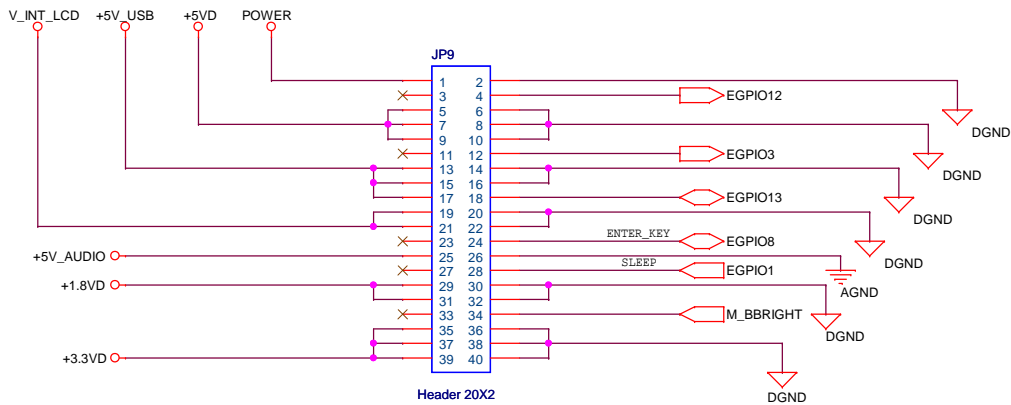
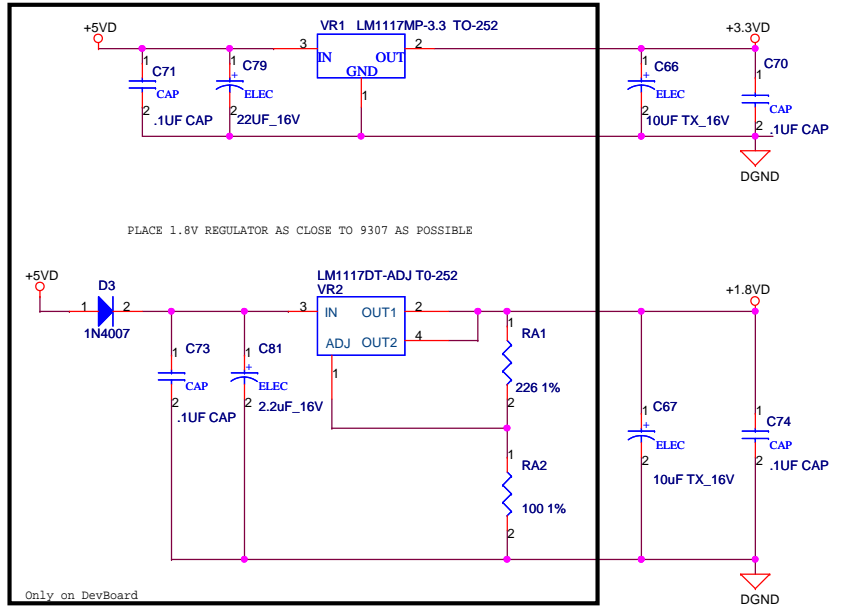
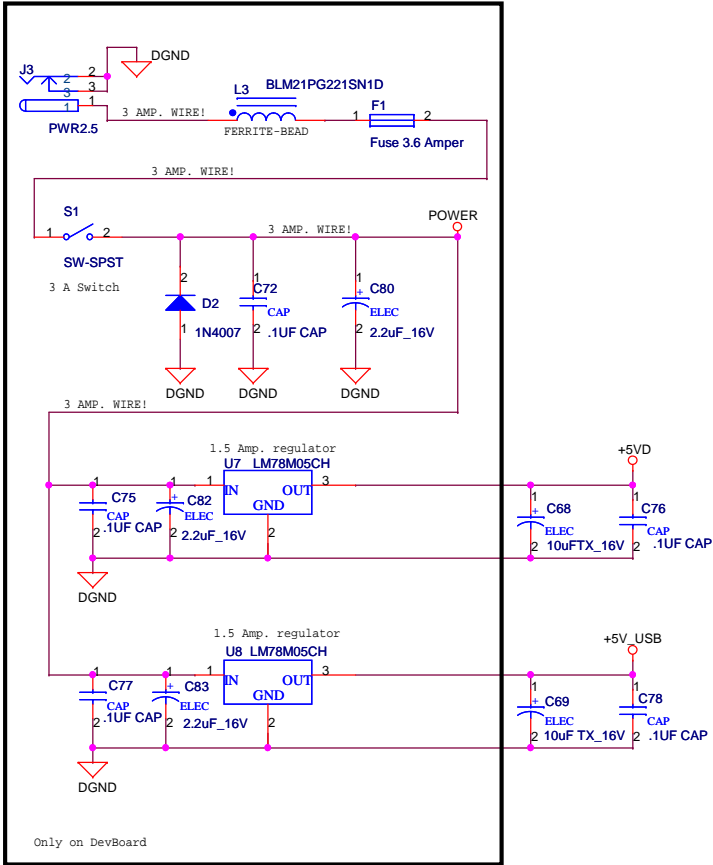

Title		
POWER SUPPLY		
Size	Document Number	Rev
B	2198	1.3
Date:	Saturday, September 19, 2009	Sheet 13 of 13